



VALVE ACCESSORIES & CONTROLS



D400

POSITIONER

VAC D400 Digital Positioner

WWW.VACACCESSORIES.COM

205-678-0507

The D400 Positioner



D400/D400 IS



D400-EX



VAC D400 Digital Positioner

The VAC D400 is a microprocessor based, "intelligent" instrument that can be mounted to rotary or linear pneumatic actuators for accurate positioner and/or process control. This unit, while sophisticated in its accuracy and performance, is simple to mount, calibrate, and with good filtered air and proper maintenance, can provide very accurate and trouble-free service for many years.

Available with Hart, Foundation Fieldbus, or Profibus communication, the D400 range of applications and communications meets the latest industry standards. The "efficiencies" of the D400 are not only in its microprocessor based technology and accuracy, but also in the pneumatic air handling where air consumption is kept to a very minimum.

D400 Options



Features and Benefits:

- Microprocessor based valve positioner
- User friendly, menu driven programming with LCD Display
- Local push button configuration—no handheld device or PC necessary
- Low air consumption and proven dependable mechanical design
- Modular design—available with position feedback, micro switches and “Fail Freeze” options. Same unit for rotary or linear mounting.
- Aluminum Housing—Nema 4X IP 65 Enclosure—Standard—Electrostatically dipped varnish with stove-hardened epoxy resin.
- Unique adaptive control feature offers the ability to enhance valve/actuator package for maximum control without upsetting the process.
- ATEX-FM-CSA-IEC-Ex approvals available



Ordering Codes:

Digital Positioner	Action	Connections	Spindle	Communications	Options
D400	S-Single	N-NPT	D1-Namur	NO-No Communication	GB-Gauge block w gauges
D400 IS (Intrinsically safe-non incensive)	D-Double	G-Metric	D2-1/2" square	H-Hart	S2-Micro Switches
**D400 EX (Explosion Proof)			D3-3/8" square	*FB-Foundation Fieldbus	4/20-Transmitter
			D4-round-linear	*PA-Profibus	FRC-Filter Regulator-coalescing
			D5-double "d"		FC-Filter Coalescing
			Dx-linear standard		FF-Fail Freeze
					A-ATEX
					G-ATEX/Gost
					PROX-NC

Example: D400-S-N-D1-H-4/20

*4/20 transmitter and switches are not available on FB and PA Bus units.

** D400 EX not available with no communication

When requesting a quote the items that can change pricing are: Positioner version, Action, Communication, Options-please have that information available for quick and accurate quotation.

VAC D400 Approvals

The D400 digital positioner has approvals for the below agencies. The details and exact listings associated with these approvals are quite extensive. Even the listing between no communication and Hart units vs. Fieldbus and Profibus can be slightly different. We have a supplemental document, entitled D400 Approval Details on our website under the D400 documentation section.

All D400 unit's enclosure are Nema 4X IP 65, Electrostatically dipped varnish with stove-hardened epoxy resin.

D400 IS	Intrinsically safe	D400 EX	Explosion Proof
FM	J.I 30005029 (3610, 3611)	FM	HLC 8/02 3010829
CSA	Certificate 1052414	Intrinsically safe	4X, T5 max 82°C
Non-incensive	Enclosure 4X, max 65°C	Non-incensive	4X, T4, max 85°C
ATEX/		Dust Ignition proof	4X, T5, max 82°C
GOST Russia		CSA	Certificate 1393820
GOST Ukraine	II 2G EEx ib IIC T6	ATEX/	
ATEX	II 2G EEx ib IIC T6	GOST Russia	
	II 2G EEx ia IIC T6	GOST Ukraine	II 2G EEx d II C T4/T5/T6
	II 3G EEx n A II T6	ATEX	II 2G EEx ib IIC T6
	II 2 D IP 6X T 46°C	IECEX	EXIB IIC T6
IECEX	Ex ib IIC T6		

Technical Information

Rotation Rev 3:	25-120 degrees	Stroke:	.4 to 4" (longer strokes-POA)
Rotation Rev 5:	25-270 degrees	Connections:	1/4" NPT Air 1/2" NPT Cable
Max Air supply	90 PSI	Air consumption:	≤.015 SCFM
Air delivery	6.0 SCFM @ 90 PSI		
Ambient temperature	-40 to 185° F		
Characteristic curves	– linear, equal %, 1:25, 1:50, 25:1, 50:1 or user configurable with 20 reference points		
Characteristic deviation	≤ 0.5%		
Deadband	0.1%, adjustable to 10%		
Resolution (A/D conversion)	16,000 steps		
Sample rate	20 msec		
Seismic vibration	Meets requirements to DIN IEC 68-3-3 Class III for strong and strongest earthquakes		
Mechanical vibration	≤ 1% up to 10 g and 10...80 Hz		
Mounting orientation	≤ 0.5% at 90° change		
EMI	complies with EMC directive 89/336/EEC as of May 1989 (increased EMI shielding to EN 50082-2 PR as of 11/93)		

Air Supply-Must be free of oil, water, and dust to DIN/ISO 8573-1 pollution and oil contents according to Class 3 dew point 10 K below operating temperatures.

D400, D400 IS

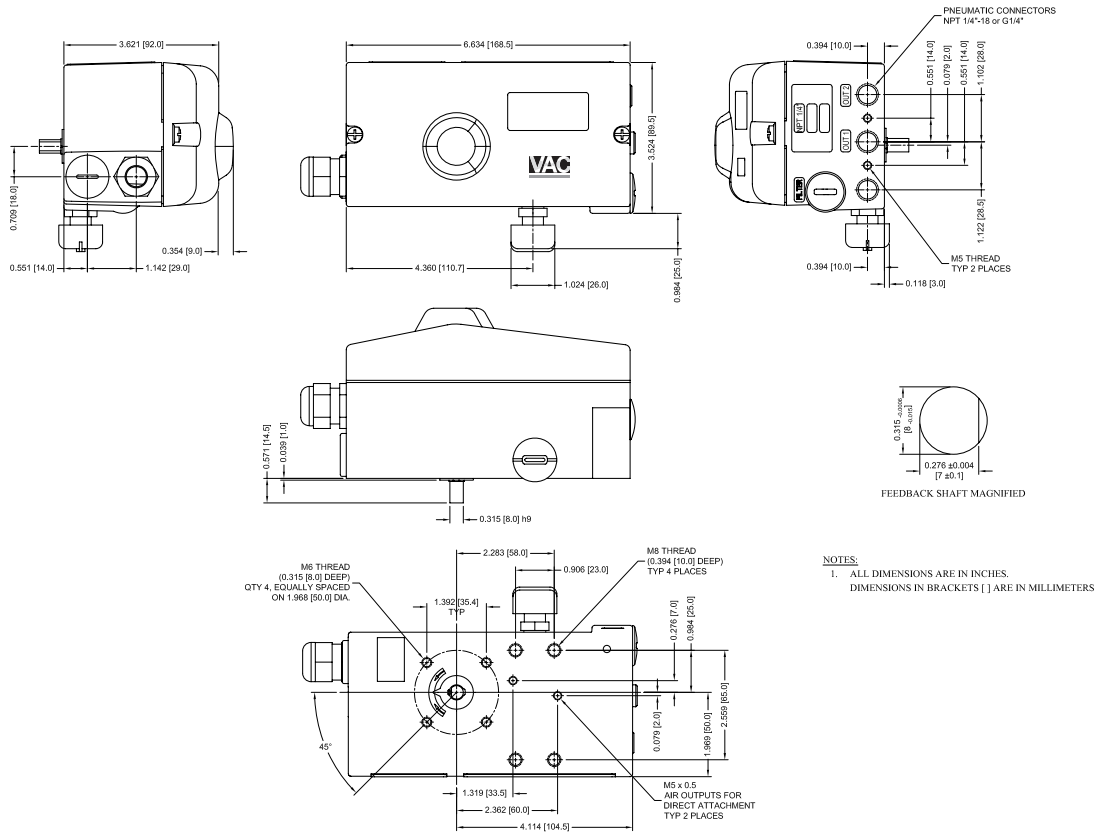

D400 EX

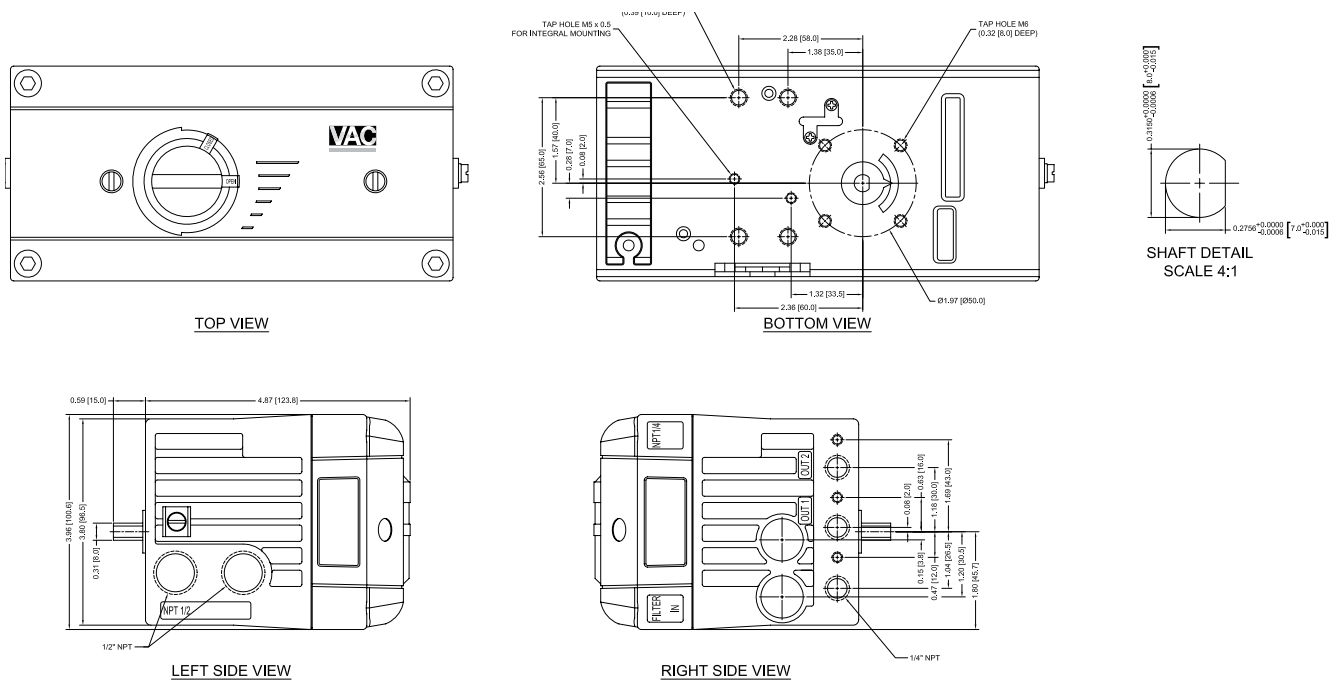



Retrofit your valve with a VAC Positioner—a “choice” of options!

Most industrial control valves are equipped with the valve manufacturer’s “standard” positioner when the valve is first delivered. As these companies move into new generation products, they often leave behind a whole marketplace of product needs that don’t “fit” the application needs. When these manufacturers’ standard positioners need replacing, what choices are you offered? High prices, poor delivery, or discontinued products leave users without many options.

From a very basic and simple, pneumatic unit to standard or EX electropneumatic, to a complete line of digital positioners, the choice of replacing the manufacturer’s “standard” positioner is back in your hands. VAC products offer the control accuracy needed in a simple rugged design (all metal housings) that is flexible and adaptable. The installed base of control valves is very important to users and to VAC.

Retrofit with a VAC positioner and take back control of your positioner options.

Our way of doing business is just as simple as our products.

A solid, simply designed positioner, with high quality construction is just the start of the Valve Accessories and Controls story. Because we are a privately held, customer-driven company, we can meet your needs much quicker, with much more flexibility.

A quality company must be more than a quality product. Responding promptly and honestly, showing genuine interest in what we do and what you do, staying focused on our strengths, and being different in a positive way are important.

Sounds simple—we plan to keep it that way!



VALVE ACCESSORIES & CONTROLS
200 Jade Park • Chelsea, AL 35043
TEL: 205-678-0507 • FAX: 205-678-0510
info@vacaccessories.com

VALVE ACCESSORIES & CONTROLS
Kevin Cowhey, Western Regional Sales Manager
Cell: 847-910-0056
kevinc@vacaccessories.com

VALVE ACCESSORIES & CONTROLS
Bob Goodwin, Eastern Regional Sales Office
Cell: 518-222-1170
bobg@vacaccessories.com

www.vacaccessories.com