



# VAC Type 400524H Lock-Up Valve Installation

## Installation:

### CAUTION!

**When installing the product please follow the procedures below.**

Always wear safety equipment and follow all safety procedures.

Please operate within the range and specified capacity in the data sheet. If exceeded the product

can be damaged and may result in injury or damage to other components.

Air must be Clean, Dry, and Non-corrosive.

Ensure that all tubing is NOT under pressure during installation.

Use a gauge when setting pressure level

Install in correct order with other devices. The lock-up valve must be connected between the positioner and the actuator. The supply to the Lock-up valve should NOT be regulated for best operation.

## Tubing Connection:

The Lock-up valve must be installed between the actuator and positioner. Follow the tubing diagrams for your actuator type Figure 1 for Double Acting, Figure 2 for Single Acting.

Lockup valve should be properly supported using the holes through the valve body. Fabrication of mounting hardware is the users responsibility.

Bench set the lockup valve using a gauge in the instrument air supply line to Port 14. Adjust the knob opposite port 14 so that when instrument air pressure falls below your desired set point that valve closes off all flow between ports 1 & 4, and 3 & 2. Turn the knob clockwise to increase the set point, counter-clockwise to decrease the set point.

Tighten the lock nut on the adjustment knob to hold the desired set point.

DO NOT Plug Port #5. This port must be able to vent to atmosphere. A bug screen or silencer is acceptable.

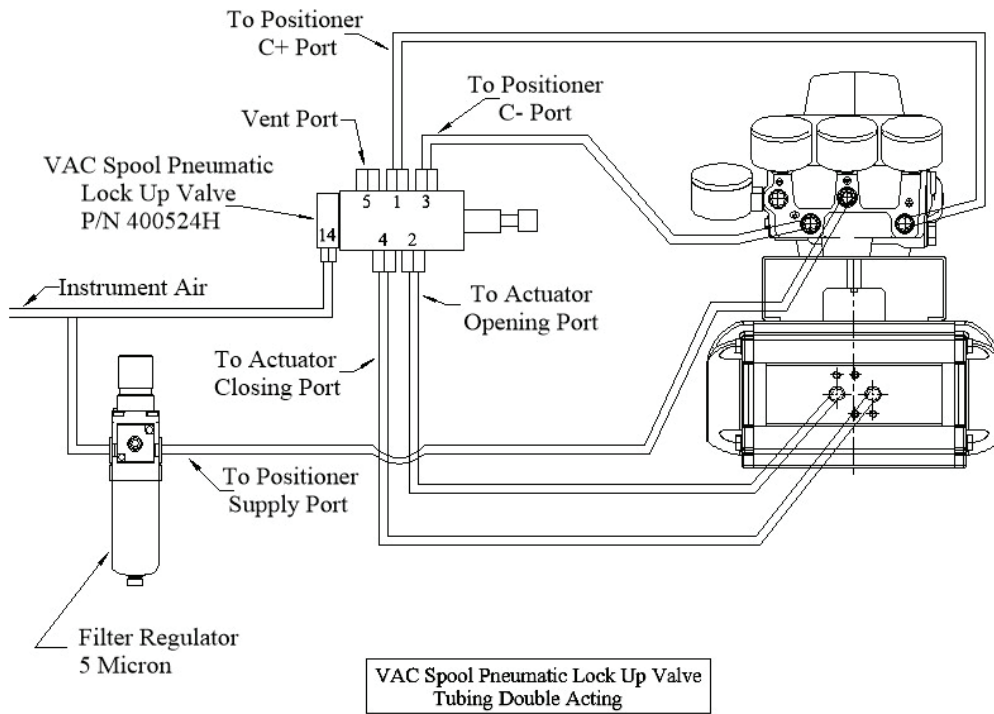

FIGURE 1

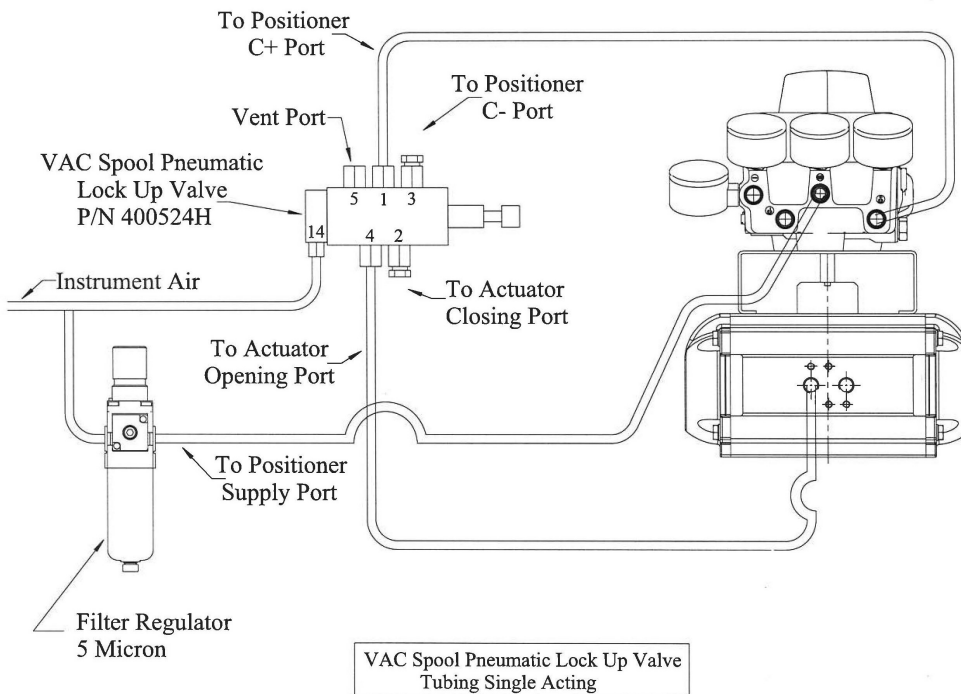

FIGURE 2