

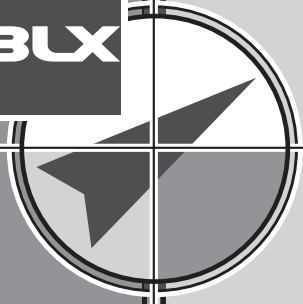

Made in Sweden



Valve Accessories & Controls.

R100 FEEDBACK

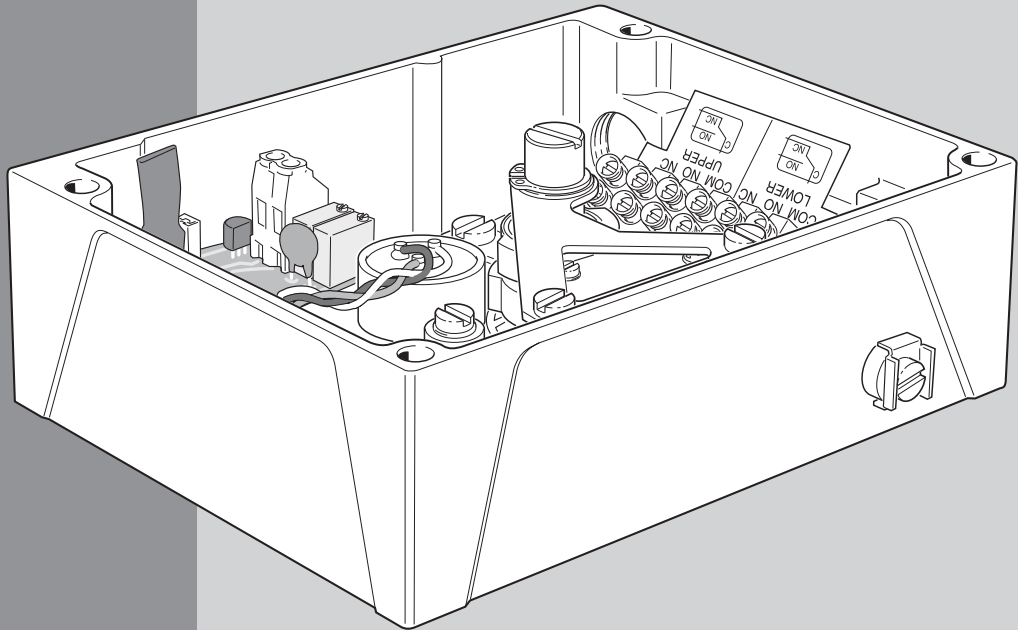

Installation



R100 Feedback

Thank you for choosing the BLX R100 Feedback

CONTENTS

1 INTRODUCTION	2
1.1 Function	2
1.2 Product Identification	2
1.3 Safety Instructions	3
2 INSTALLATION	3
2.1 Connections	3
2.2 Installation on V100 Positioner	4
2.3 Switch connection	5
2.3.1 Switch activating point adjustment	5
2.3.2 Electrical installation	5
2.4 Position transmitter connection	6
2.4.1 Connecting the control signal	6
2.4.2 Transmitter Jumper settings	6
2.4.3 Potentiometer adjustment	7
2.4.4 Position transmitter calibration	7
2.5 Front cover and Indicator	8
3 DIMENSIONS	9



R100 Feedback

1 INTRODUCTION

1.1 Function

The BLX R100 feedback unit allows for accurate position feedback, where on-off indication (mechanical switches) or 4-20mA transmitter or potentiometer is required. Feedback units can be factory or field mounted to the V100 positioner with no additional parts or mounting brackets required, thus creating a very compact package.

The positioner/switch package is completely sealed.

R100 is connected to the positioner drive shaft(1) which in turn is connected to the actuator output shaft.

A position change moves the R100 spindle and cam(2) which will activate a switch(3). The 4-20mA position transmitter(4) will proportionally change the output signal of the actuator/valve package.

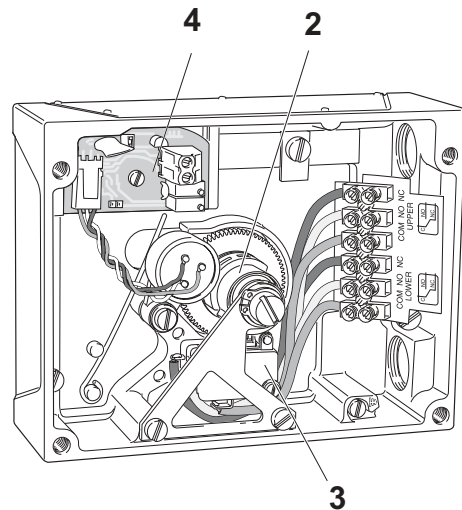
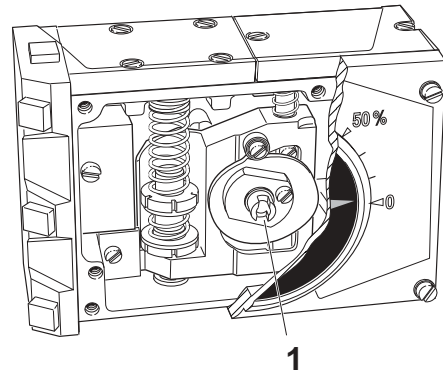

1.2 Product identification

The R100 has two identification tags, the serial number tag(1), and the product model tag(2). The latter contains information on electrical rating and temperature ranges. Other information can be shown depending on the model.

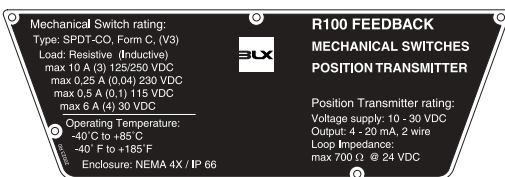
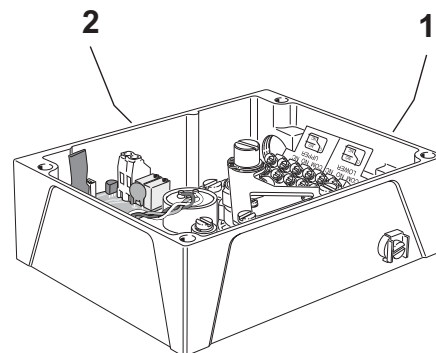

The product model tag for R100-M-mA



The serial number tag. Unique number



R100 Feedback

1.3 Safety Instructions



CAUTION: Beware of moving parts when Positioner/Feedback unit is operated!



CAUTION: Beware of parts with live voltage!
Voltage, which can be dangerous is supplied to the feedback unit. Avoid touching or short circuiting live parts, bare wires, as well as the housing.



CAUTION: Do not exceed the feedback performance limitations!
Exceeding the limitations marked on the feedback unit label may cause damage to the feedback unit. Damage or personal injury may result.

2. INSTALLATION

2.1 Connections

E_1 – Cable entry

E_2 – Cable entry

\perp – Grounding point
– Internal and External

1. – Terminal block, switches
2 X 3 Connections
Max cable area 2.5 mm², AWG ~13

2. – Terminal block, Position Transmitter
Max cable area 2.5 mm², AWG ~13

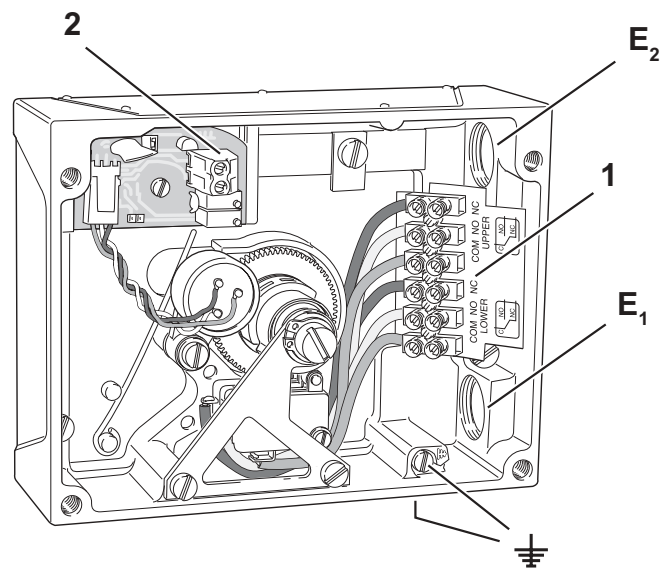

Cable entries for male 1/2" NPT, PG 13.5 or M20 cable fitting.

The appropriate threads are clearly marked on the housing.



R100 Feedback

2.2 Installation on V100 Positioner.

While the R100 can be mounted to the positioner first, it is best to install the V100 Positioner on the Actuator,(see V100 manual) calibrate the positioner, and then mount the R100 unit.

1. Remove the front cover and indicator on the V100 positioner. (see page 8)
2. Check the O-ring(1) in the bottom of the feedback unit.
3. Place the feedback over the positioner. Using a screw driver in the slot(2), press down and turn the spindle until the feedback spindle aligns in the Positioner drive shaft slot(3). No special or extra parts are needed.

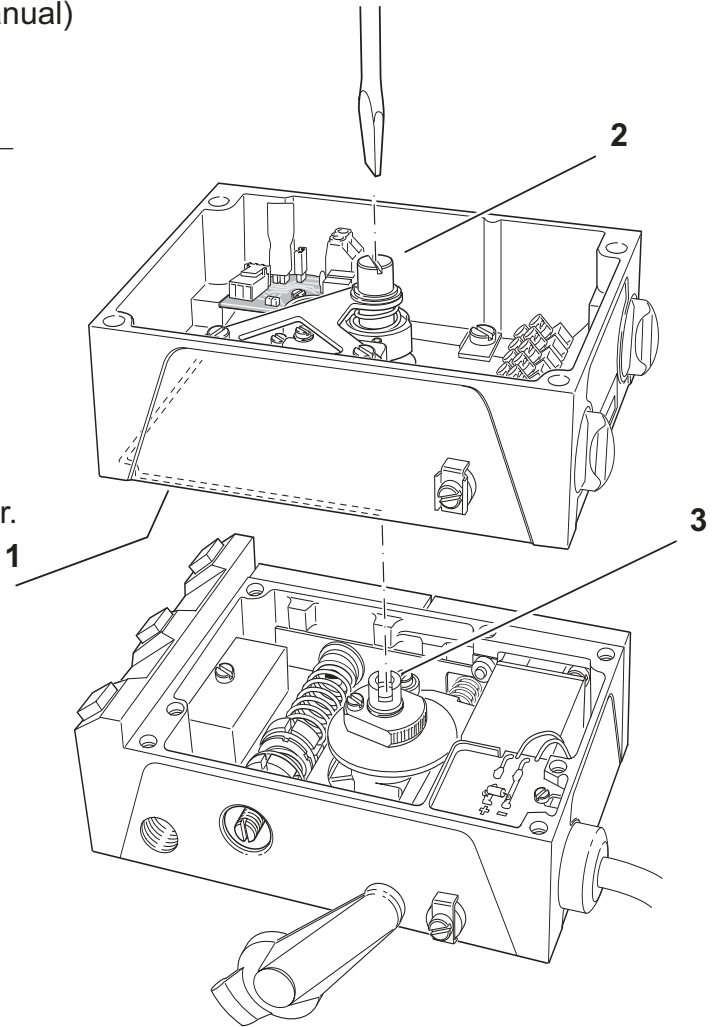

Check the mounting, there should be no gap between the feedback unit and positioner. Tighten the three screws(4).

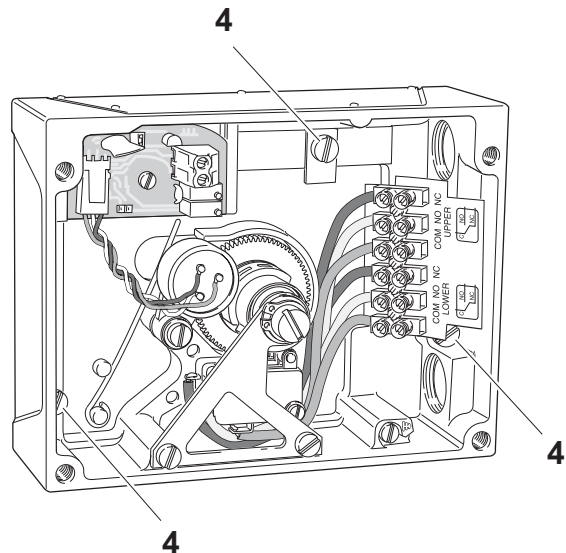



R100 Feedback

2.3 Switch connection.

2.3.1 Switch activating point adjustment.

With the front cover and indicator removed, (see page 8) the switch activating point is adjusted by releasing and turning the spring loaded cams(1, 2). Lift the upper cam and press down the lower cam. The cams are spring loaded and self locking.

1. With a meter properly connected, set the cam function to either normally open(NO) or normally closed(NC).
2. Stroke the valve/actuator to the desired position. Adjust the cam to measure the activation point. Run the valve to the next position and repeat the adjustment on the second cam.
Double check the activation points.

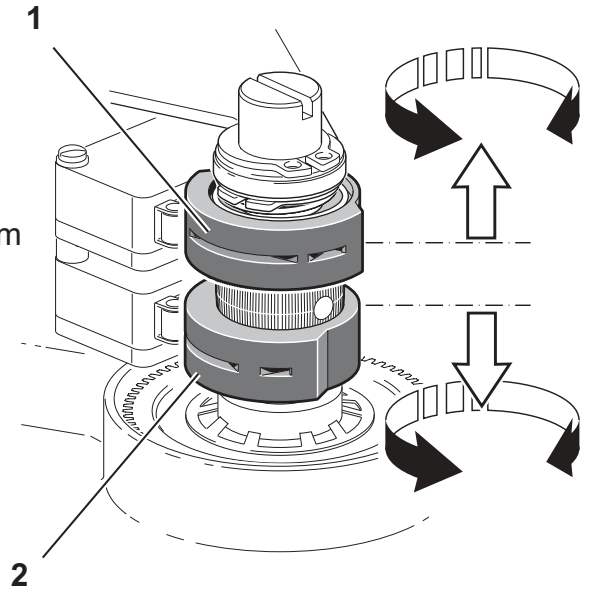

2.3.2 Electrical installation

Connect your control system/equipment cables to the terminal block(3)
Maximum cable area 2.5 mm², ~AWG 13.

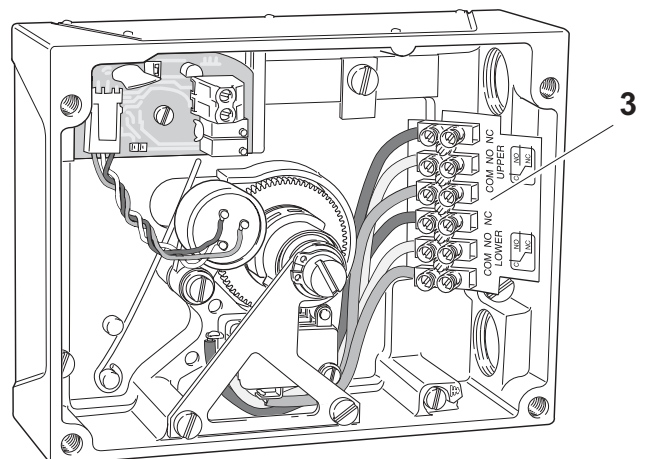



R100 Feedback

2.4 Position transmitter connection

2.4.1 Connecting the control signal

1. Remove the front cover and indicator. (see page 8)
2. Connect the signal cable to the respective pole on terminal block(1).

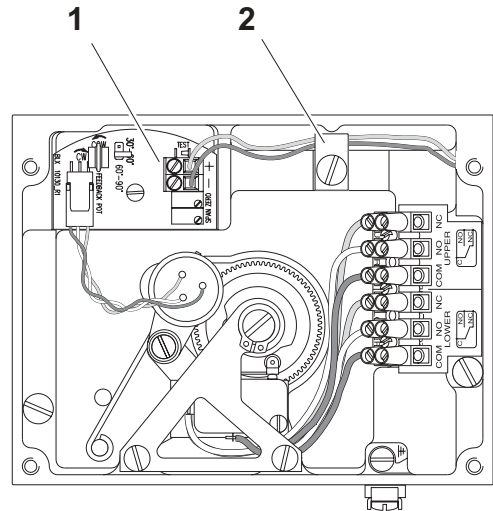

Max cable area 2.5 mm², ~AWG 13

We recommend that the cables are secured under the holder(2) to protect the cables from vibration damages.

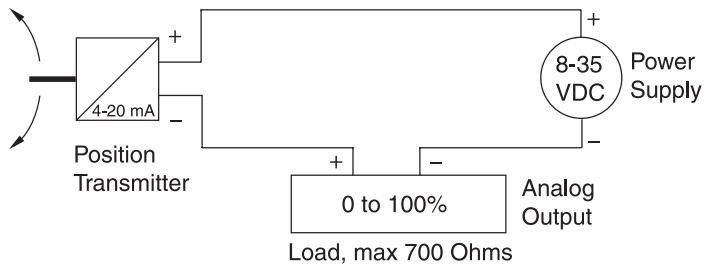

2.4.2 Transmitter Jumper settings

 **The Position Transmitter is standard shipped with the Jumpers set for direct (CCW) turning, range 60°-90°**

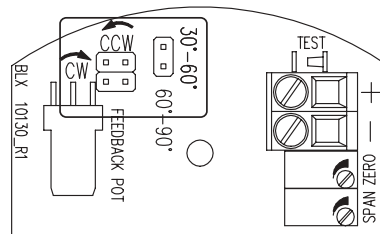

Determine the direction for increasing mA output. Direct (CCW) or Reverse (CW) and the turning range 30°-60° or 60°-90°.

1. Direct (CCW) turning
Range 60°-90°
2. Direct (CCW) turning
Range 30°-60°
3. Reverse (CW) turning
Range 60°-90°
4. Reverse (CW) turning
Range 30°-60°

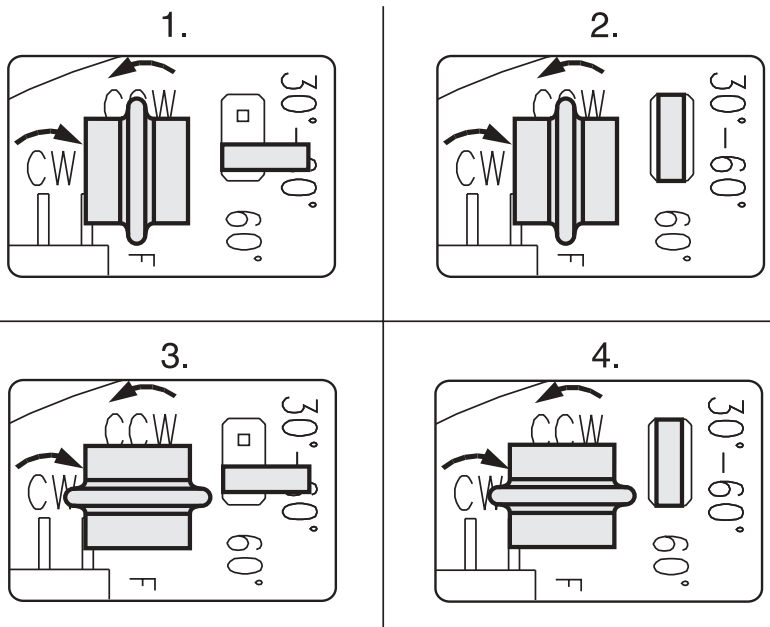



R100 Feedback

2.4.3 Potentiometer adjustment

1. Power up the current loop.
2. Connect a low ohmic ampere meter over the test points(3).
3. Run the valve/actuator to closed (4 mA) position.
4. Move the potentiometer gear away(4) from the drive gear(5).
5. Rotate the potentiometer gear(4) until you read 3.5 - 4.5 mA on the meter.
(fine adjustment is done on the transmitter card, see 2.4.4)

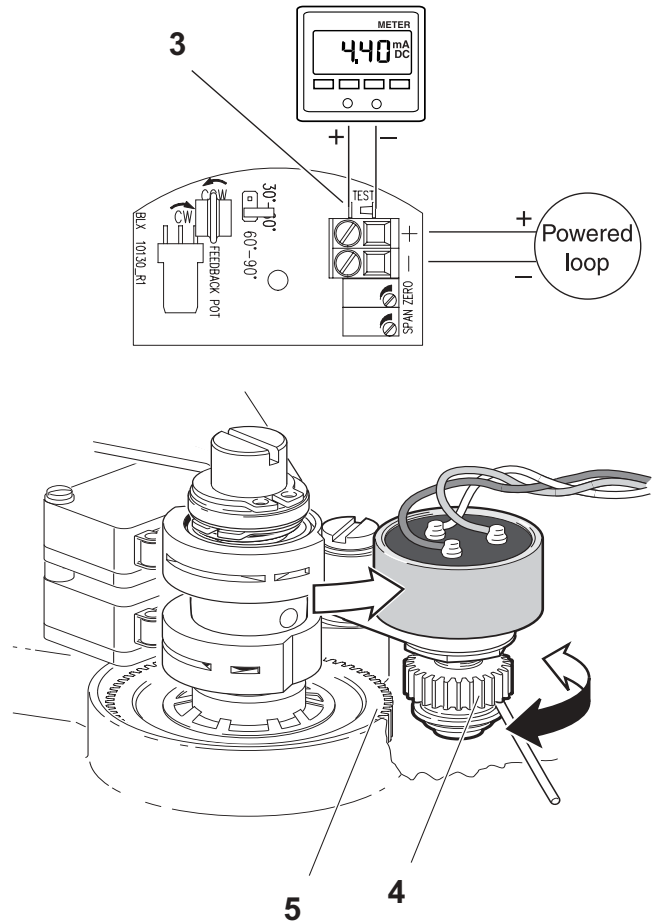

2.4.4 Position transmitter calibration

1. Power up the current loop.
2. Connect a low ohmic ampere meter over the test points(3).
3. Run the valve/actuator to 4 mA position.
4. Adjust potentiometer(6) so that the meter reads 4mA.
5. Run the valve/actuator to 20mA position.
6. Adjust potentiometer(7) marked span until the meter reads 20mA.

 **The Position Transmitter is shipped standard for 90° direct (CCW) turning.**

Check the zero position
Make fine adjustments if necessary.

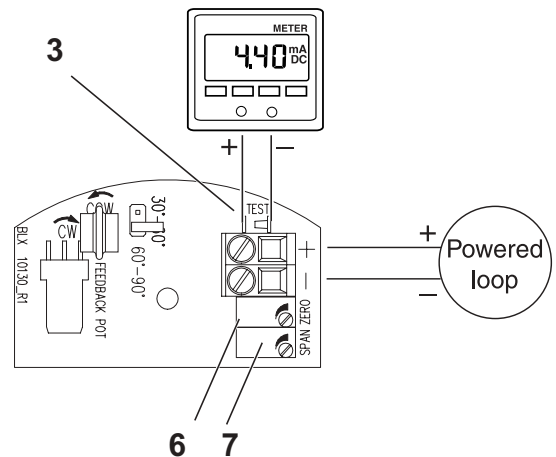



R100 Feedback

2.5 Front cover and indicator

Removing the front cover

Loosen the four screws(1) and remove the front cover.

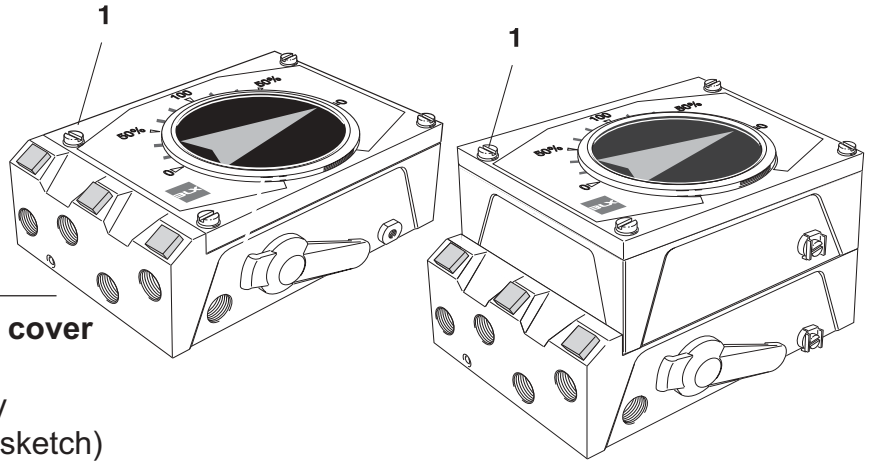

Changing the sealing in the front cover

1. Remove the indicator cover(2) by pressing from the backside.(see sketch)
2. Remove the rubber gasket(3) and replace with a new gasket.
3. Remove the O-ring (4) on the back side of the front cover and replace with a new O-ring.
4. Install the flat indicator cover by aligning its tap into the groove(5) of the front cover and lock(snap) it in place. The beacon has no tap and just snaps in place.

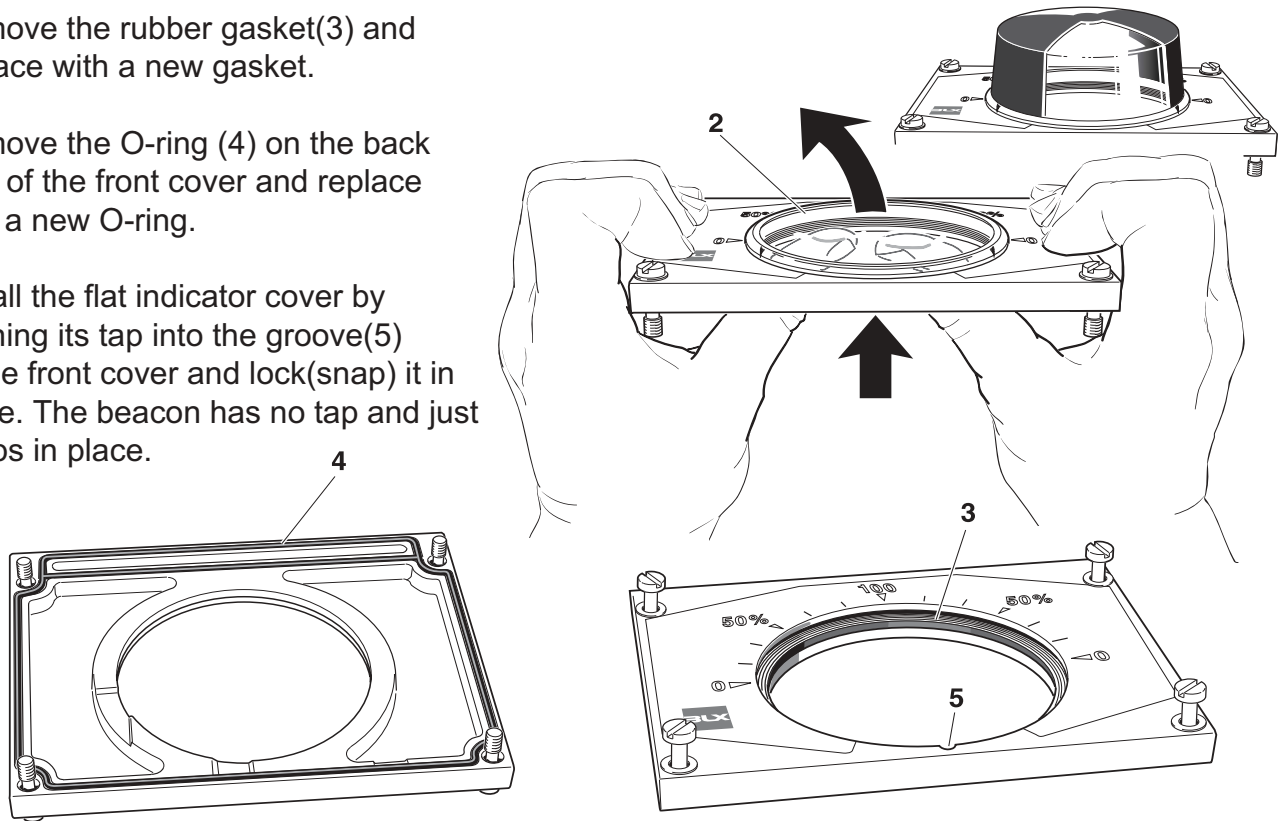

Removing the indicator

Pull the indicator(6) straight up.

Important Note!

Note the indicator's position for remounting.

Mounting the indicator

Install the indicator in place over the drive shaft and press it straight down. Turn the indicator to the proper display position.

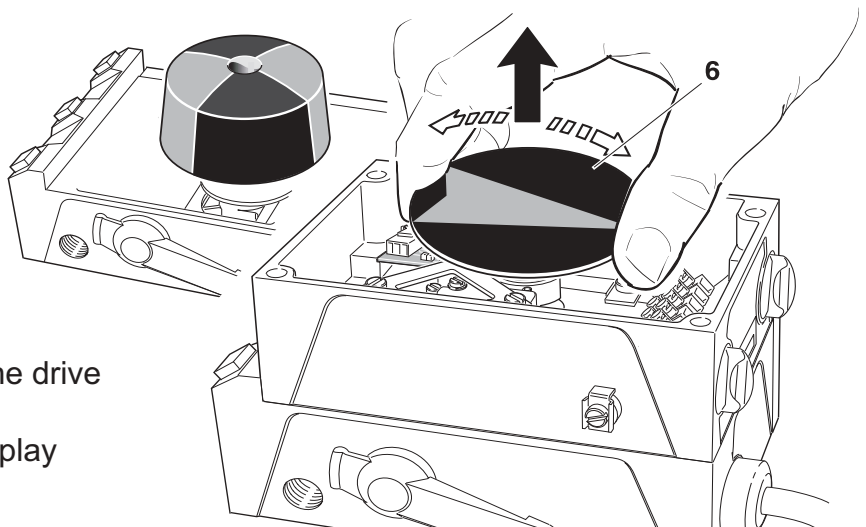



R100 Feedback

3. DIMENSIONS

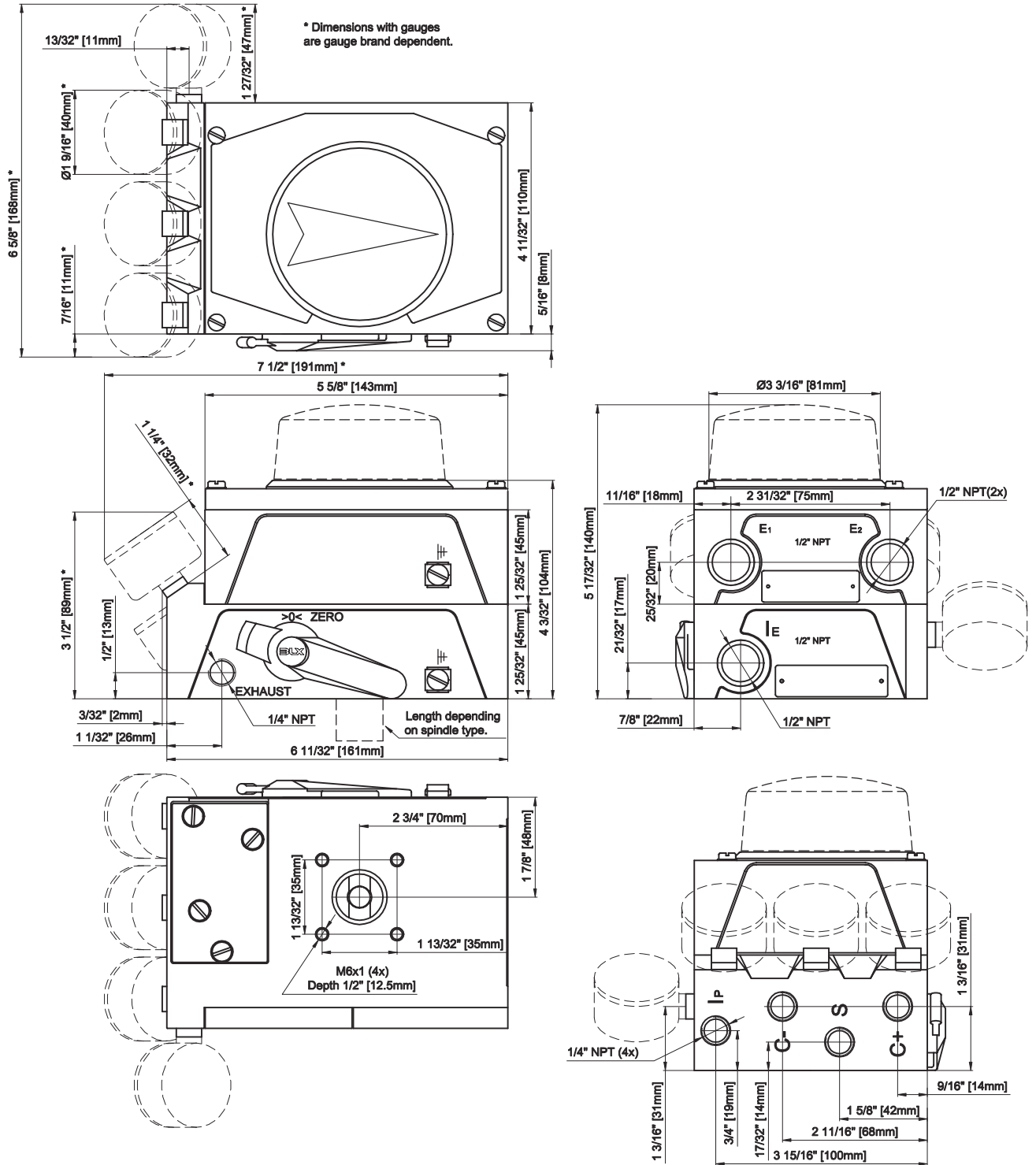



www.vacaccessories.com

Valve Accessories & Controls, Inc.

200 Jade Park

Chelsea, AL 35043

TEL: (11) 205-678-0507 • FAX: (11) 205-678-0510

vacaccessories.com