

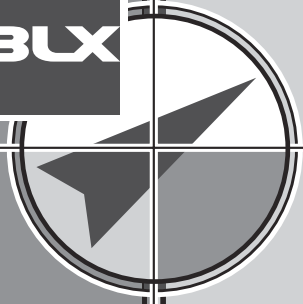

Made in Sweden



Valve Accessories & Controls.

# R300 FEEDBACK

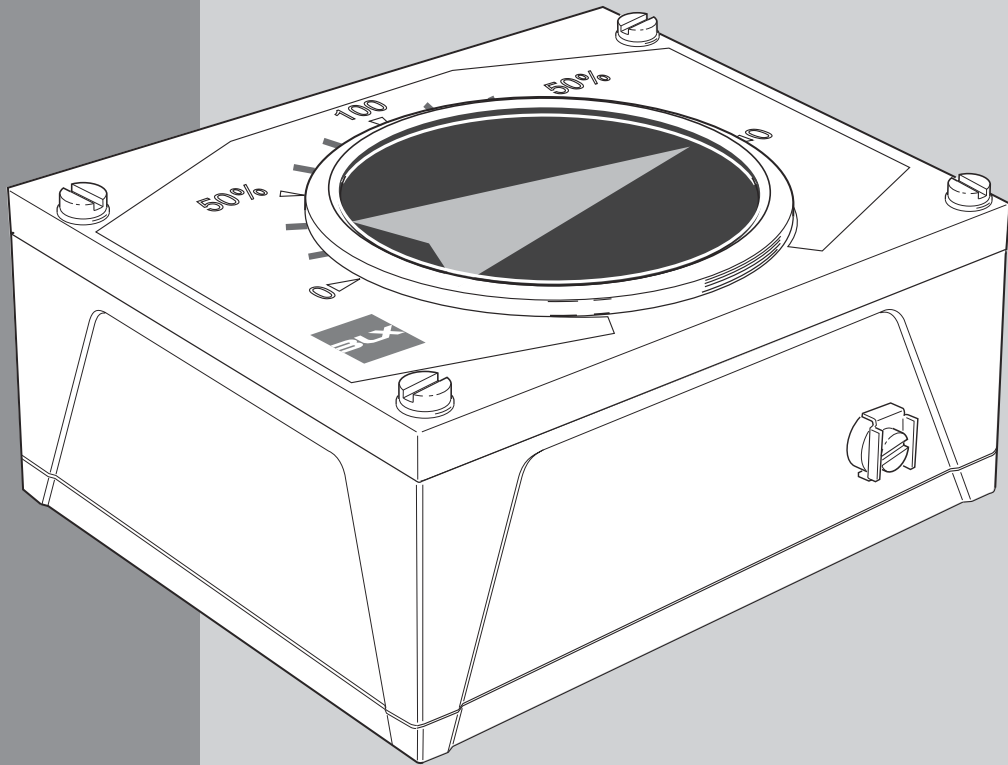

# Installation



# R300 Feedback

---

Thank you for choosing the BLX R300 Feedback

## CONTENTS

<b>1 INTRODUCTION .....</b>	<b>2</b>
1.1 Function .....	2
1.2 Product Identification .....	2
1.3 Safety Instructions .....	3
<b>2 INSTALLATION .....</b>	<b>3</b>
2.1 Connections .....	3
2.2 General mounting instructions .....	4
2.3 Switch connection .....	5
2.3.1 Switch activating point adjustment.....	5
2.3.2 Electrical installation .....	5
2.4 Position transmitter connection .....	6
2.4.1 Connecting the control signal .....	6
2.4.2 Transmitter Jumper settings.....	6
2.4.3 Potentiometer adjustment .....	7
2.4.4 Position transmitter calibration .....	7
2.5 Front cover and Indicator .....	8
<b>3 DIMENSIONS .....</b>	<b>9</b>



# R300 Feedback

## 1 INTRODUCTION

### 1.1 Function

The BLX R300 feedback unit allows for accurate position feedback, where on-off indication (mechanical switches) or 4-20mA transmitter or potentiometer is required. The positioner/switch package is completely sealed.

R300 is connected to the actuator output shaft via the drive.

A position change moves the R300 spindle and cam(1) which will activate a switch(2). The 4-20mA position transmitter(3) will proportionally change the output signal of the actuator/valve package.

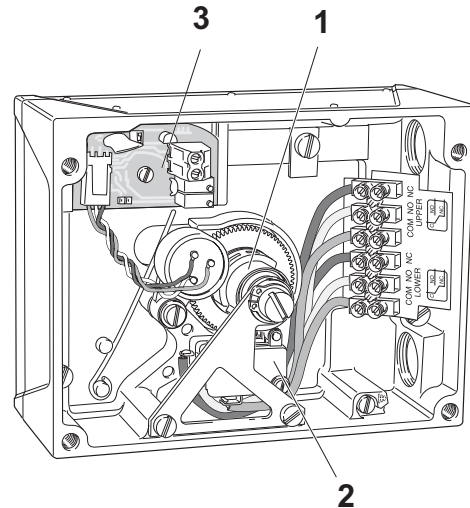

### 1.2 Product identification

The R300 has two identification tags, the serial number tag(1), and the product model tag(2). The latter contains information on electrical rating and temperature ranges. Other information can be shown depending on the model.

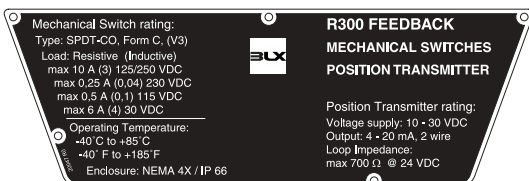
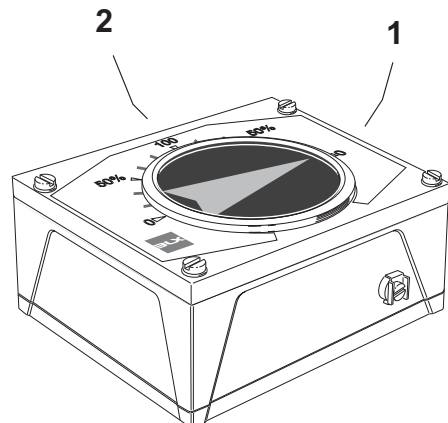

The product model tag for R300-M-mA



The serial number tag. Unique number



# R300 Feedback

## 1.3 Safety Instructions



**CAUTION: Beware of moving parts when Positioner/Feedback unit is operated!**



**CAUTION: Beware of parts with live voltage!**  
Voltage, which can be dangerous is supplied to the feedback unit. Avoid touching or short circuiting live parts, bare wires, as well as the housing.



**CAUTION: Do not exceed the feedback performance limitations!**  
Exceeding the limitations marked on the feedback unit label may cause damage to the feedback unit. Damage or personal injury may result.

## 2. INSTALLATION

### 2.1 Connections

$E_1$  – Cable entry

$E_2$  – Cable entry

$\perp$  – Grounding point  
– Internal and External

1. – Terminal block, switches  
2 X 3 Connections  
Max cable area  $2.5 \text{ mm}^2$ , AWG ~13

2. – Terminal block, Position Transmitter  
Max cable area  $2.5 \text{ mm}^2$ , AWG ~13

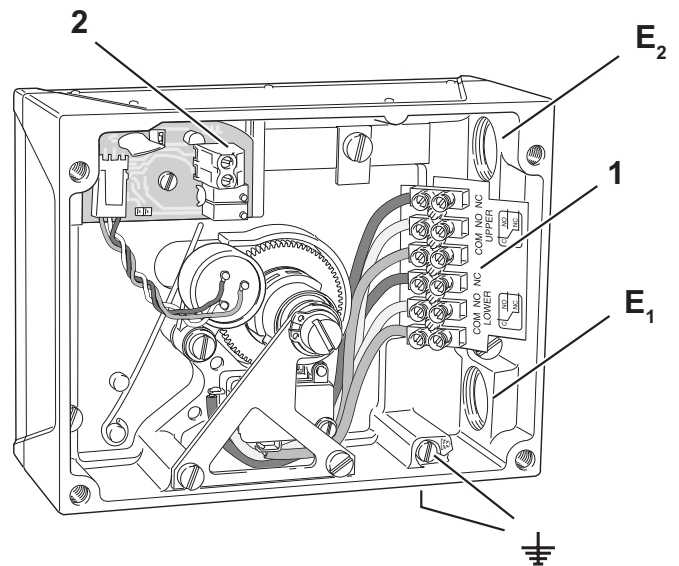

Cable entries for male 1/2" NPT, PG 13.5 or M20 cable fitting.

The appropriate threads are clearly marked on the housing.



# R300 Feedback

## 2.2 General mounting instructions.

The R300 has both the ISO F05 hole pattern(1) and the 2¼" x 2¼" mounting square(2) for mounting kits.

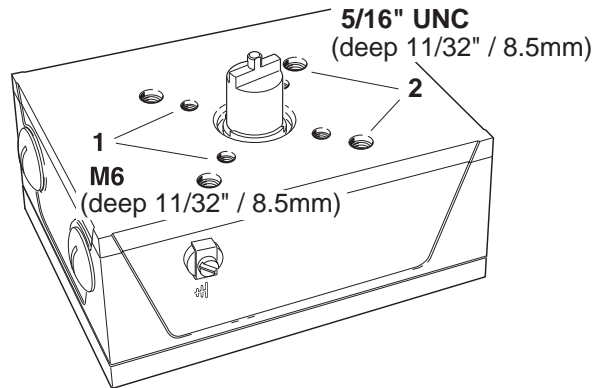

### 2.2.1 Rotary actuator

The BLX R300 has a very stable and properly sized drive shaft bearing. However, the Feedback unit drive(A) should be aligned properly to the rotary actuator spindle(B). A relatively small error combined with a rigid coupling can create very powerful radial forces, which can in turn overload and in short time wear out even the very best drive shaft bearing.

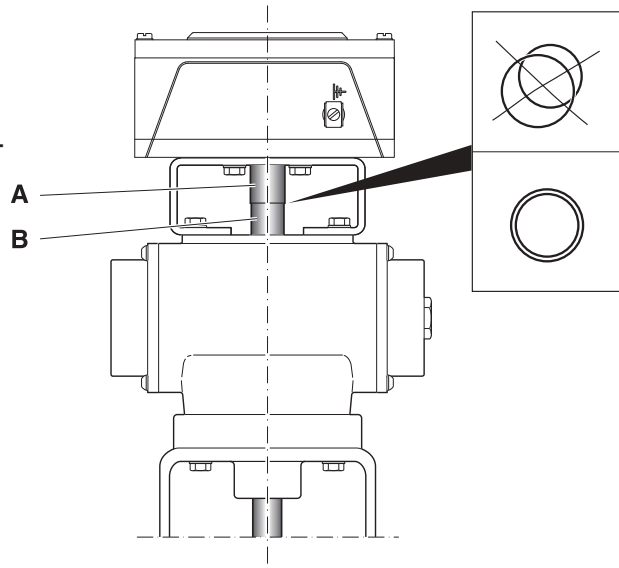

### 2.2.2 Linear actuator

When mounting on linear actuators, the feedback unit should be attached in such a way that its drive is in the center of the actuator's stroke. Proper installation and alignment will minimize linearity error.

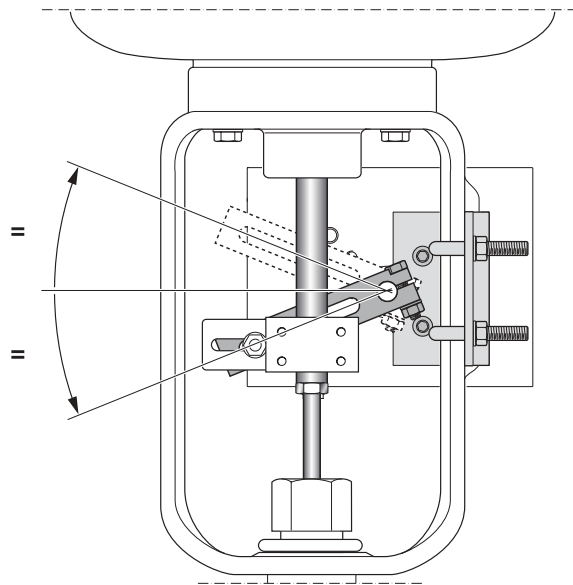



# R300 Feedback

## 2.3 Switch connection.

### 2.3.1 Switch activating point adjustment.

With the front cover and indicator removed, (see page 8) the switch activating point is adjusted by releasing and turning the spring loaded cams(1, 2). Lift the upper cam and press down the lower cam. The cams are spring loaded and self locking.

1. With a meter properly connected, set the cam function to either normally open(NO) or normally closed(NC).
2. Stroke the valve/actuator to the desired position. Adjust the cam to measure the activation point. Run the valve to the next position and repeat the adjustment on the second cam.  
Double check the activation points.

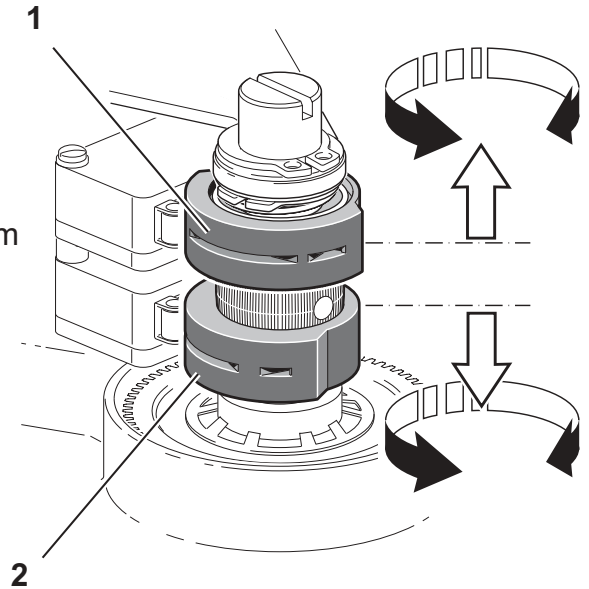

### 2.3.2 Electrical installation

Connect your control system/equipment cables to the terminal block(3)  
Maximum cable area 2.5 mm<sup>2</sup>, ~AWG 13.

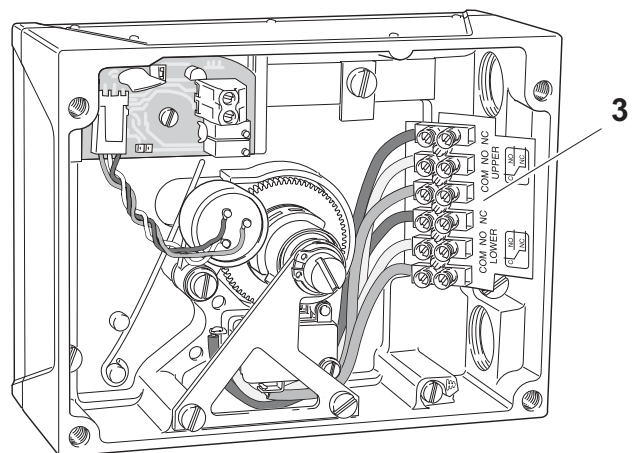



# R300 Feedback

## 2.4 Position transmitter connection

### 2.4.1 Connecting the control signal

1. Remove the front cover and indicator. (see page 8)
2. Connect the signal cable to the respective pole on terminal block(1).

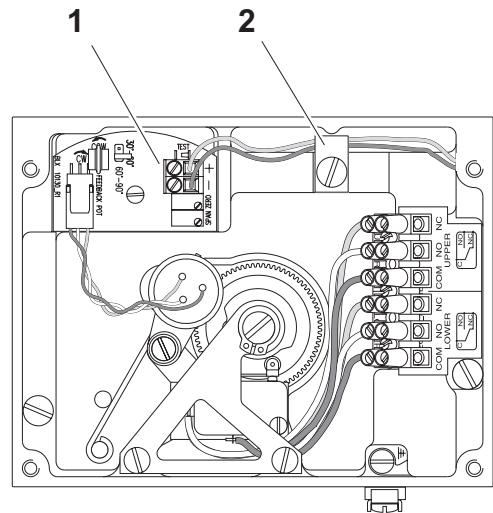

Max cable area 2.5 mm<sup>2</sup>, ~AWG 13

We recommend that the cables are secured under the holder(2) to protect the cables from vibration damages.

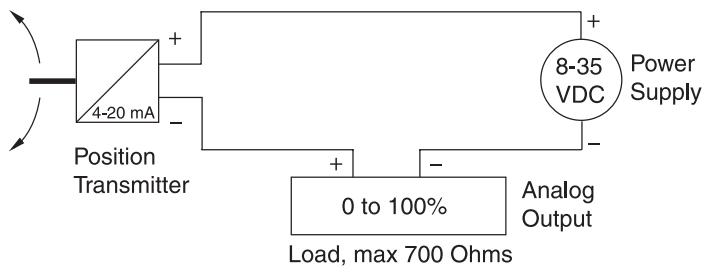

### 2.4.2 Transmitter Jumper settings

 **The Position Transmitter is standard shipped with the Jumpers set for direct (CCW) turning, range 60°-90°**

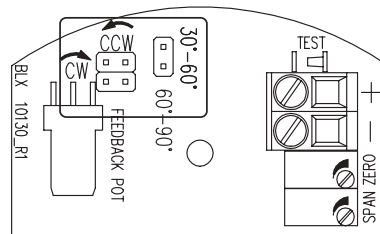

Determine the direction for increasing mA output. Direct (CCW) or Reverse (CW) and the turning range 30°-60° or 60°-90°.

1. Direct (CCW) turning  
Range 60°-90°
2. Direct (CCW) turning  
Range 30°-60°
3. Reverse (CW) turning  
Range 60°-90°
4. Reverse (CW) turning  
Range 30°-60°

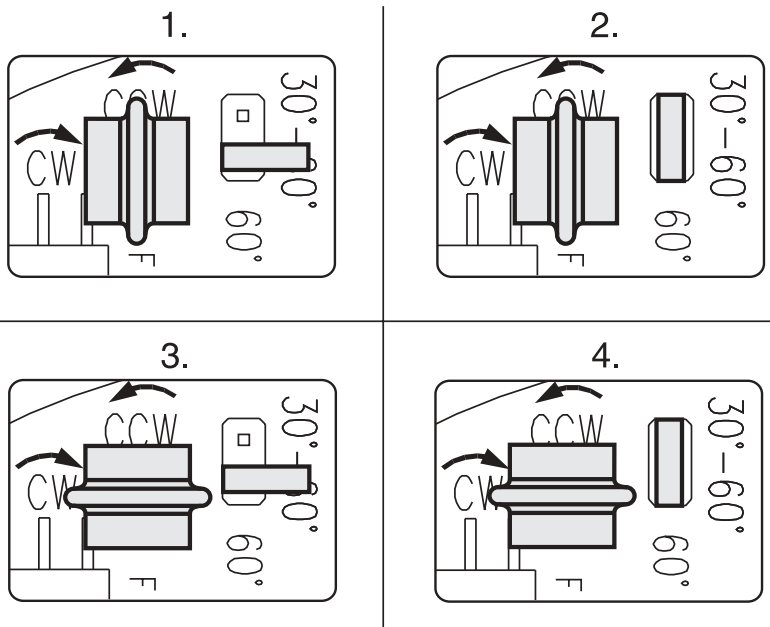



# R300 Feedback

## 2.4.3 Potentiometer adjustment

1. Power up the current loop.
2. Connect a low ohmic ampere meter over the test points(3).
3. Run the valve/actuator to closed (4 mA) position.
4. Move the potentiometer gear away(4) from the drive gear(5).
5. Rotate the potentiometer gear(4) until you read 3.5 - 4.5 mA on the meter.  
(fine adjustment is done on the transmitter card, see 2.4.4)

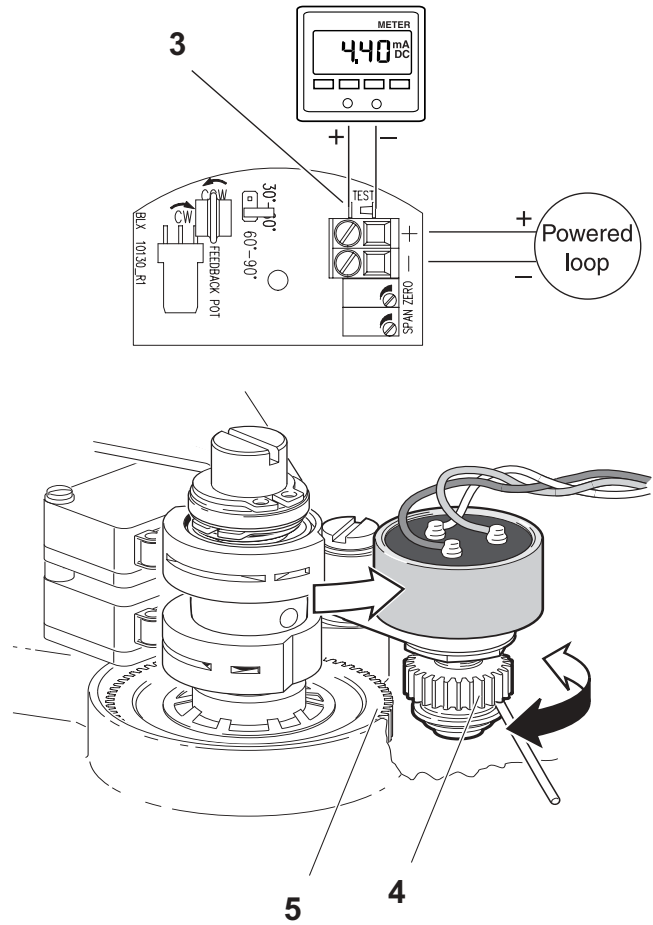

## 2.4.4 Position transmitter calibration

1. Power up the current loop.
2. Connect a low ohmic ampere meter over the test points(3).
3. Run the valve/actuator to 4 mA position.
4. Adjust potentiometer(6) so that the meter reads 4mA.
5. Run the valve/actuator to 20mA position.
6. Adjust potentiometer(7) marked span until the meter reads 20mA.

 **The Position Transmitter is shipped standard for 90° direct (CCW) turning.**

Check the zero position  
Make fine adjustments if necessary.

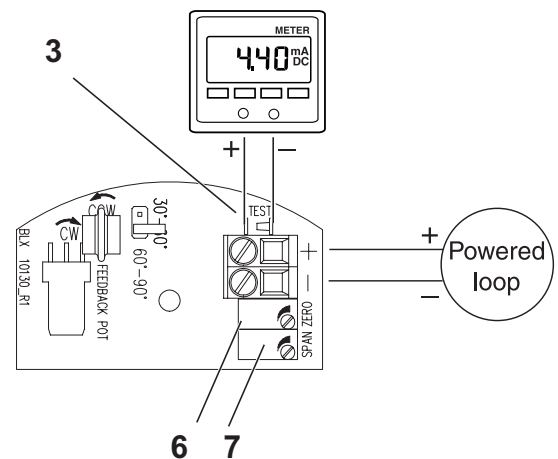





# R300 Feedback

## 2.5 Front cover and indicator

### Removing the front cover

Loosen the four screws(1) and remove the front cover.

### Changing the sealing in the front cover

1. Remove the indicator cover(2) by pressing from the backside.(see sketch)
2. Remove the rubber gasket(3) and replace with a new gasket.
3. Remove the O-ring (4) on the back side of the front cover and replace with a new O-ring.
4. Install the flat indicator cover by aligning its tap into the groove(5) of the front cover and lock(snap) it in place. The beacon has no tap and just snaps in place.

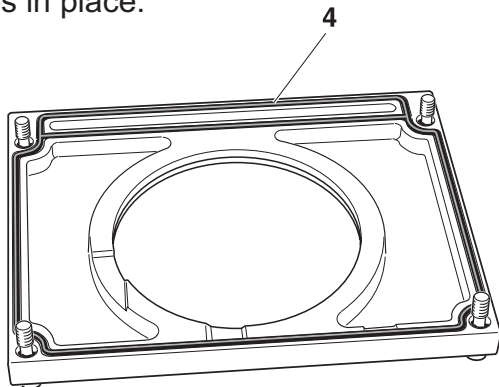
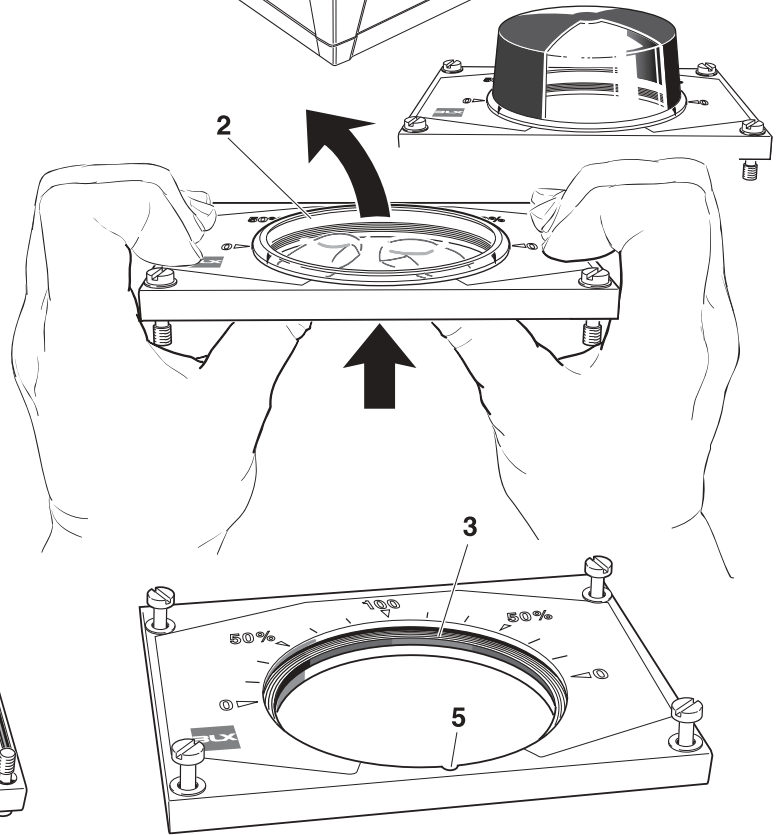
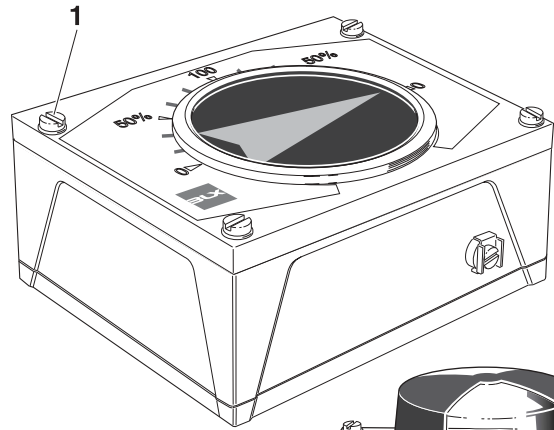

### Removing the indicator

Pull the indicator(6) straight up.

### Important Note!

Note the indicator's position for remounting.

### Mounting the indicator

Install the indicator in place over the drive shaft and press it straight down. Turn the indicator to the proper display position.

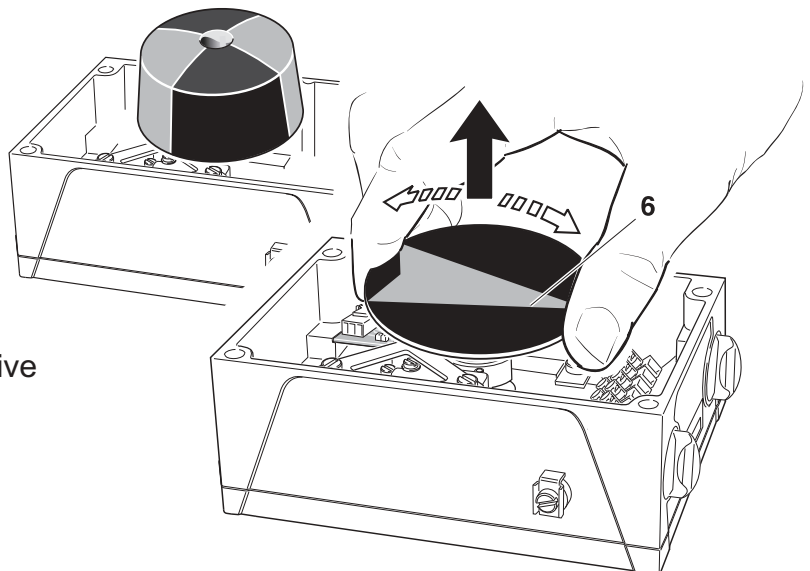

## 3. DIMENSIONS

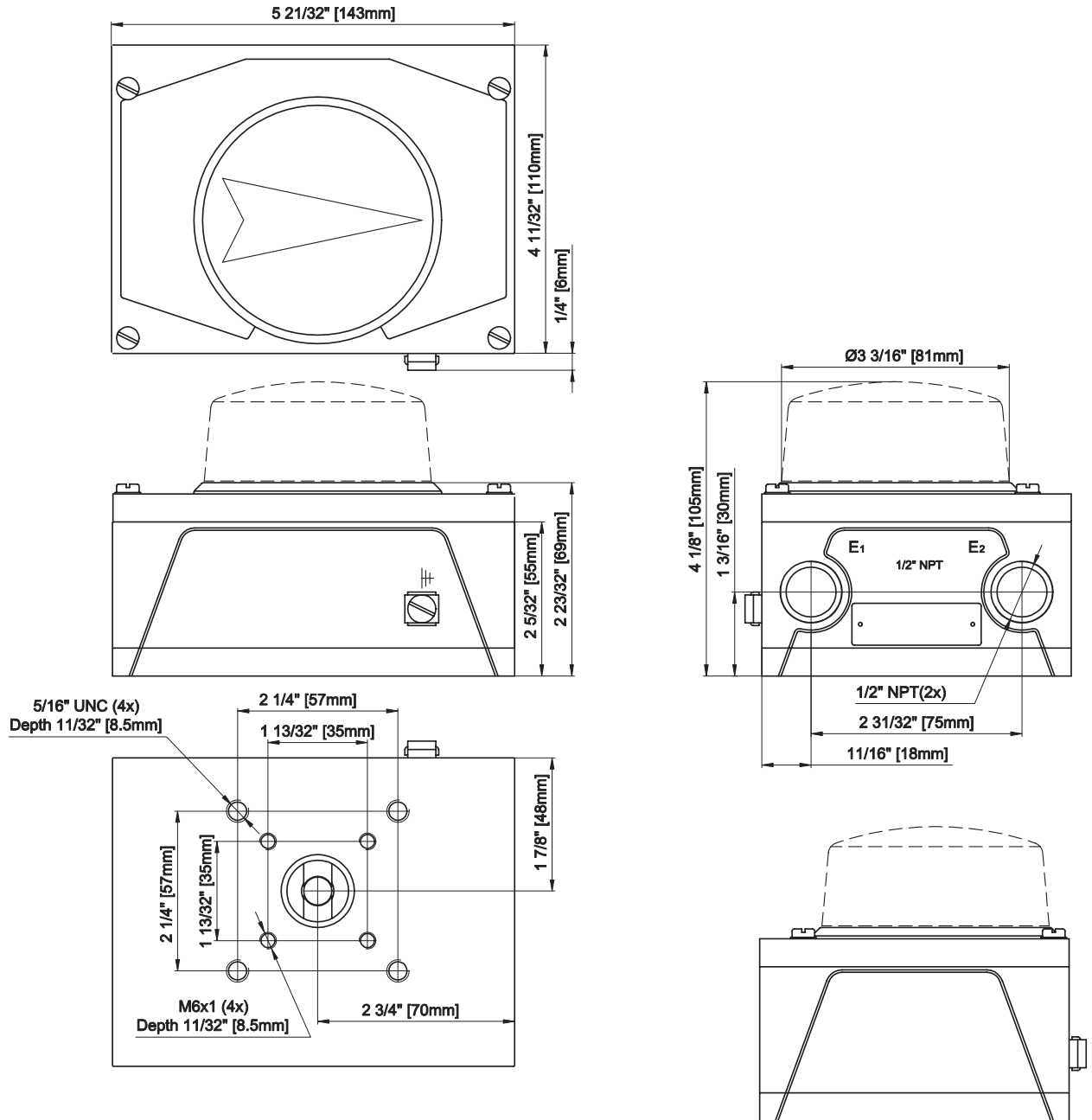



**VALVE ACCESSORIES &  
CONTROLS, INC.**  
200 Jade Park  
Chelsea, AL 35043  
TEL: 205-678-0507  
FAX: 205-678-0510

Valve Accessories & Controls LTD.  
Unit 201, Solent Business Centre  
Millbrook Road West  
Southampton • S015 OHW  
TEL: (44) 023 8078 7534  
FAX: (44) 023 8078 7631  
vacnigelc@aol.com

[vacaccessories.com](http://vacaccessories.com)