



Trouble Shooting guide for V200 Positioner

1) V200 not responding to input signal

a) The tubing to the actuator may be incorrect

- i) Plant Air Supply should be ported to the S port on the side of the positioner. Supply must be greater than 30 PSI.
- ii) The pneumatic control signal (3 to 15 psi) should be ported to the I port on the side of the positioner. If the positioner is a V200E, using an I/P on the positioner, the I port should be plugged tightly!! Double check once plug is in place to make sure there is no air leakage from I plug.
- iii) The driving port of this positioner is the C+ port. In other words, on an increasing control signal the supply is directed through the positioner to the C+ port. This is very important – not only for single acting or spring assist valve packages, but also to insure proper air to open (or close) operation (rotation).

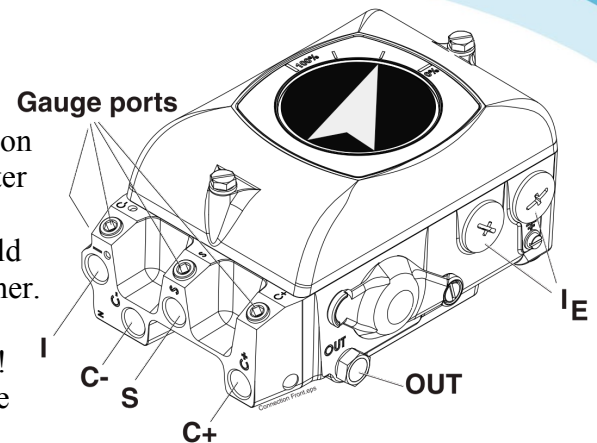

b) I/P wiring

- i) Make sure the unit is properly wired.
 - (1) The positive terminal (+) MUST have a positive voltage to it.
 - (2) The negative terminal (-) MUST have a negative voltage to it.

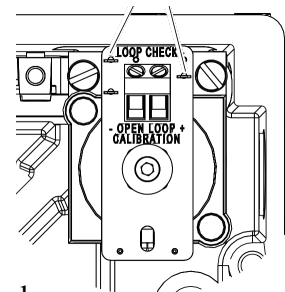

c) I/P operation

- i) If the I/P has been in use the potential for contaminated air supply exist – check the I/P by either of the following steps.
 - (1) Install a gauge on the I/P gauge port (1/8 inch NPT) to make sure that the I/P is generating a 3 to 15 psi pneumatic output in correlation to the 4 to 20 mA input signal.
 - (2) Using an ohm meter check to make sure that there is resistance still in the loop. A good unit will put out 240 Ω or more.

d) Cam

- i) If cam nut and locking screw are not correctly inserted the positioner will not work correctly, generally resulting in the cam slipping and a small input change will equal a full stroking of the actuator. Make sure that the locking screw is all the way out before you tighten the cam nut; then secure the locking screw (the cam nut is the first lock – the screw is the second lock). The cam pictured below is INCORRECT, and will result in cam slipping and full stroking of the actuator on small input changes.

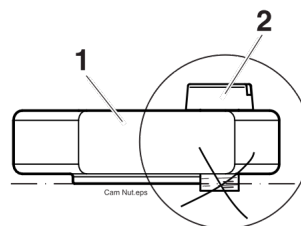

- ii) Make sure that the Positioner action (direct acting or reverse acting) corresponds with the cam. A “D” or an “R” can be found on the cam to indicate direction of cam rotation.

- (1) An easy way to check this is to remove the cover of the positioner and watch the rotation to ensure that cam placement is correct.

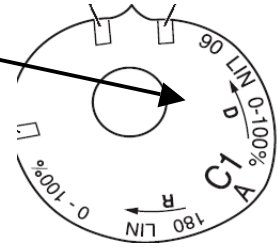

e) Spool Valve

- i) Dirty air can cause particulates to cause “sticking” and prevent the positioner from working correctly. (see below hunting)

- (1) Remove the spool valve and blow out with air. If air is not available wipe down with cloth. Once cleaned the spool piece should slide very easily in its housing. Place spool valve back into positioner making sure that the slotted top of the spool piece is connected correctly on the balance arm.

f) Gauge Plugs

- i) All gauge plugs or gauges must be secure (no air leaks!!). If the plugs or gauges are not properly tightened air can leak causing the positioner not to respond to input signal. Note: gauges are very useful when trouble shooting a positioner. This helps “inspect” the air flow through the positioner as well as the I/P output. Three 0-160 psi gauges are used for the supply (S port) and two output ports (C+ and C-). A 0-30 psi gauge is used for the I/P output.

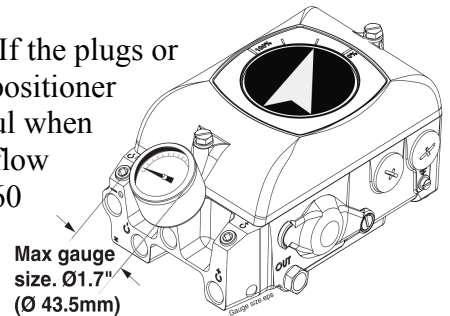

g) Mounting

- i) Rotary

- (1) The positioner will not work correctly if the positioner is not engaged properly in the actuator. Check the positioner to actuator coupling to see if the positioner and actuator are mated correctly.

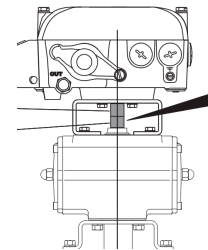

- ii) Linear

- (1) Slop – can result when the actuator to positioner

components are loose or improperly connected.

A linear arm is what converts the linear motion to a rotary motion for the positioner. If there is slop or play in the assembly, it can cause the positioner not to perform correctly. A rule of thumb when mounting on linear actuators is when

at 50% of input signal the linear arm should be at mid stroke, thus making a 90 angle with the linear arm and the valve stem.

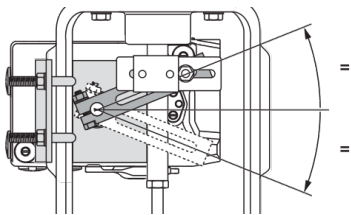

2) Hunting or Oscillation

a) Spool Valve

(1) Remove the spool valve and blow out with air. If air is not available wipe down with cloth. Something every soft, like a pipe cleaner should be used to clean the inside of the spool block itself. Once cleaned the spool piece should slide very easily within the housing. Place spool valve back into positioner making sure that the top of the spool piece is connected correctly on the balance arm.

(a) DO NOT USE WD40 or OIL BASED LUBRICANTS TO CLEAN SPOOL PIECE.

(2) Due to our superior air delivery sometimes on small actuators this can cause hunting to occur. This can also occur when dealing with damper drives as well, do to the weight and stroke of the damper.

(a) If there are doubts on which spool valve to order call our service center at 205.678.0507

(b) Replace standard spool valve with the Low Gain spool valve. VAC will do an exchange at no cost.