

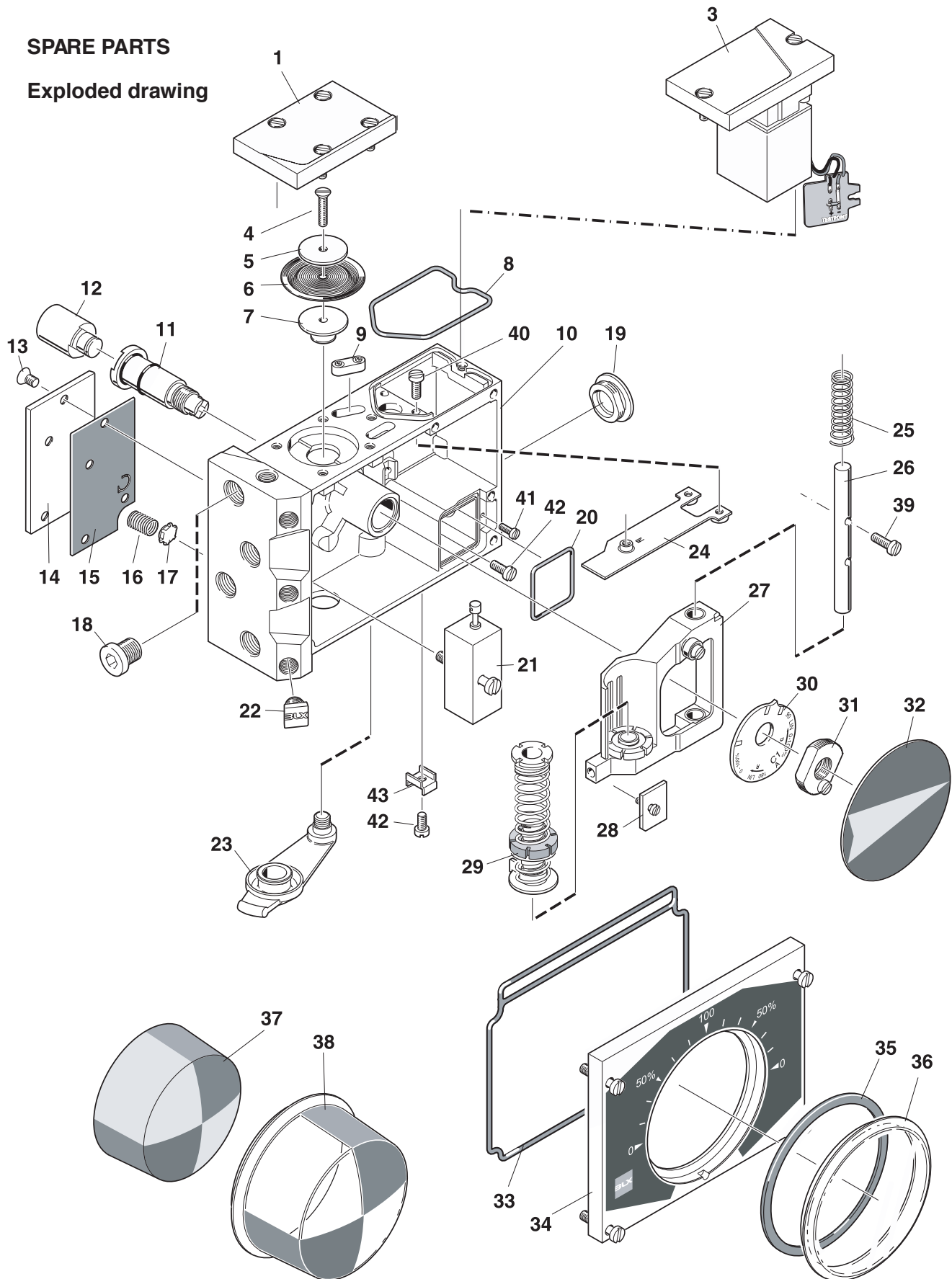

# V100 Positioner

## SPARE PARTS

Exploded drawing



**V100E Electropneumatic Positioner**

<b>Item</b>	<b>Description</b>	<b>Part No.</b>	<b>Qty</b>
1	Membrane Cover	400299	1
	Includes Screw MCS 5x14-5 SS		4
	Mylar Washer	400277	4
	O-ring 5x2 NBR		1
3	I/P Converter	400105	1
	Includes connection card		
	Screw MCS 5x14-5SS		1
	Screw MCS 5x12-5 SS		1
	Mylar Washer	400277	2
4	Screw MKFS 4x14 SS		1
5	Membrane Washer	400303	1
6	Membrane	400263	1
7	Membrane Piston	400262	1
4,5,6,7	Membrane Assembly	<b>400296</b>	
8	O-ring 54x2.5 NBR		1
9	Filter Cap	400260	2
10	Positioner Housing		1
	Bearing 15x8		
11	Drive Shaft	400295	1
	O-ring 15x2 NBR		1
	O-ring 12x1.5 NBR		1
12	Drive/Spindle		1
	Spring Circlip		1
13	Screw MFS 5.8 SS		4
14	Tightening Cover	400255	1
15	Back cover plate gasket	400268	1
16	Safety Valve Spring	400258	1
17	Safety Valve Plug Nitrile	400269	1
19	“Blind Plug NPT 1/2”	400270	1
	Includes Blind Plug M20x1.5		1
	Blind Plug PG 13.5		1
	O-ring 18.5x1.5 NBR		1
21	Pilot Valve W1 (Low Gain)	400101	1
	Pilot Valve W2 ( High Gain)	400102	1
	Pilot Valve W3 ( Standard Gain)	400100	1
	Includes Screw MCS 5.25-5 SS		1
	O-ring 5x1.5 NBR		5
	Valve Gasket	400293	1
22	Gauge Plug	400253	4
23	Zero Plug Nitrile	400264	1

**V100E Electropneumatic Positioner**

<b>Item</b>	<b>Description</b>	<b>Part No.</b>	<b>Qty</b>
24	Balance Arm	400252	1
25	Retainer Spring	400256	1
26	Guide Pin	400267	1
27	Guide Arm Assembly	400294	1
	Includes ball bearing		1
	Zero Screw		1
	Screw MCS 4x10 SS		1
	Bearing 8.8		2
28	Stop Washer	400254	1
	Includes Screw MCS 4x8-4 SS		1
29	Feedback Spring Assembly 3-15	400287	1
	Feedback Spring Assembly 6-30	400288	1
30	Cam (C1 is standard)		1
31	Cam Nut	400251	1
	Includes Screw MCS 4x8 SS		1
32	Indicator Arrow	400250	1
	Includes Circlip SGA 15 SS		1
33	Front Cover O-ring Nitrile	400278	1
34	Front Cover Assembly	400201	1
	Includes Front Cover O-ring		1
	Std 90 degree mylar label		1
	Screw MCS 5x20-5 SS		4
	Mylar Washer	400277	4
35	Indicator Gasket Nitrile	400276	1
36	Indicator Cover Flat	400249	1
37,38	Indicator Raised/Beacon	400150	1
	Includes Circlip SGA 15 SS		1
39	Screw MCS 4x16 SS		2
40	Screw MCS 4x10 SS		2
41	Screw MCS 3x10 SS		1
42	Screw MCS 4x8 SS		2
43	Grounding Clamp	400259	1

\*\*Cams with other ranges, Front labels with other scale readings and Drives suitable for the most frequently used actuator types are available