



V200 POSITIONER

www.vacaccessories.com

SPARE PARTS

V200 EX GAS

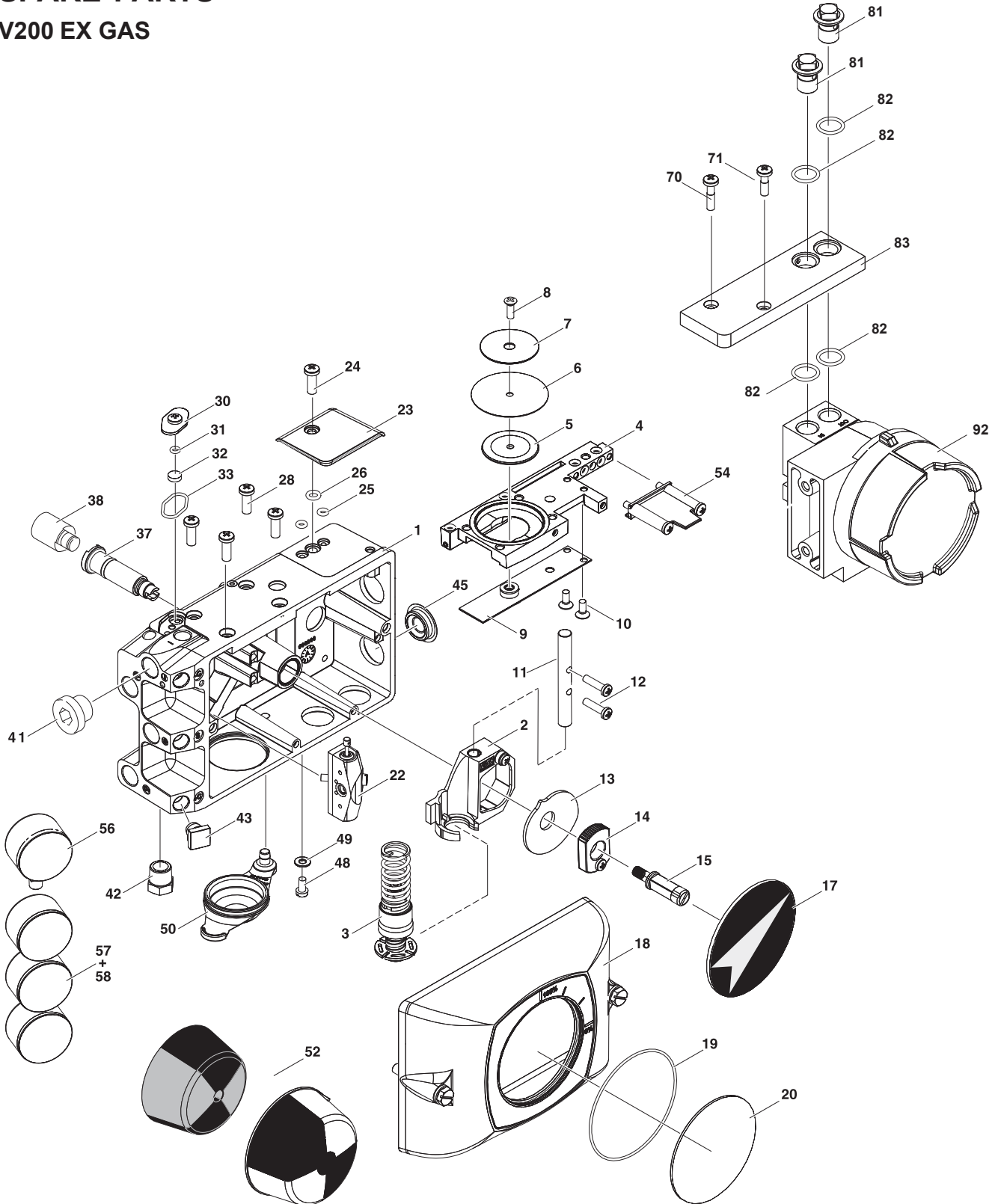



V200 EX Gas Positioner

Item	Description	Part No.	Qty
1	Housing		1
2	Feedback Arm Assembly	4091002	1
	Includes Arm, Ball Bearing		1
	Screw ISO 1207 M4x12		1
	Bearing 8x8		2
	Pin ISO 8752 2.5x8		1
3	Feedback Spring Assembly 3-15 PSI	4091018	1
	Feedback Spring Assembly 6-30 PSI	4091019	1
4	Membrane Plate Assembly	4090081	1
5,6,7,8	Included in above, membrane piston		1
	Membrane, washer, screw		1
9	Balance Arm (included with FB arm assy)		1
10	Screw ISO 1207 M4x8		2
	Included with balance arm		
11	Guide Pin	4090024	1
	Included with feedback arm assembly		1
12	Screw ISO 1207 M4x14		2
13	Cam (C1 is Standard)	Varies	1
14	Cam nut and screw	4090030	1
15	Indicator screw		1
17	Indicator Arrow	4090049	1
18	Front cover assembly	4091001	1
19	Indicator cover o-ring	4090039	1
20	Indicator Cover Flat	4090038	1
21	Front Cover O-ring Nitrile	4092002	1
22	Pilot Valve (SG/LB)	4091010	1
22	Pilot Valve HG (High Gain)	4091008	1
22	Pilot Valve (SHGHF) Super High Gain High Flw	4091011	1
23,24	Top Cover Plate with screw	4090080	1
30 -33	Filter Cover Plate Assembly	4090032	1
37	Drive Shaft	4090029	1
38	Spindle (D1 is standard)	Varies	1
41	"Stainless Steel 1/4"" I/P Plug"	400261	1
42	Bug screen/Silencer	400149	1
43	"1/8"" plastic gauge plug"	4090618	4
45	Blind Plug	4093017	1
50	Zero Plug	4090037	1
52	Dome Indicator Kit (yellow/black)	4090038	1
52	Dome Indicator Kit (red/green)	4093010	1
70-92	I/P converter Kit	4091006G	1
54	E to P conversion plate	4091000	1

**Cams with other ranges, Front labels with other scale readings and Drives suitable for the most frequently used actuator types are available